

ಕರ್ನಾಟಕ ಶಾಲಾ ಪರೀಕ್ಷೆ ಮತ್ತು ಮೌಲ್ಯನಿರ್ಣಯ ಮಂಡಲಿ

ಮಲ್ಲೇಶ್ವರಂ, ಬೆಂಗಳೂರು - 560 003

KARNATAKA SCHOOL EXAMINATION AND ASSESSMENT BOARD
Mallechwaram, Bengaluru - 560 003

ರಾಜ್ಯ ಮಟ್ಟದ ಎಸ್.ಎಸ್.ಎಲ್.ಸಿ. ಪೂರ್ವಸಿದ್ಧತಾ ಪರೀಕ್ಷೆ,
ಫೆಬ್ರವರಿ/ಮಾರ್ಚ್ - 2024

STATE LEVEL SSLC PREPARATORY EXAMINATION,
FEBRUARY/MARCH - 2024

ವಿಷಯ ಸಂಕೇತ : **83-E**

Subject Code : **83-E**

ವಿಷಯ : ವಿಜ್ಞಾನ

Subject : SCIENCE

(ಭೌತ ವಿಜ್ಞಾನ, ರಸಾಯನ ವಿಜ್ಞಾನ ಮತ್ತು ಜೀವ ವಿಜ್ಞಾನ / **Physics, Chemistry & Biology**)

(ಇಂಗ್ಲಿಷ್ ಮಾಧ್ಯಮ / **English Medium**)

ದಿನಾಂಕ : 01. 03. 2024]

[Date : 01. 03. 2024

ಸಮಯ : ಮಧ್ಯಾಹ್ನ 2-00 ರಿಂದ ಸಾಯಂಕಾಲ 5-15 ರವರೆಗೆ] [Time : 2-00 P.M. to 5-15 P.M.

ಗರಿಷ್ಠ ಅಂಕಗಳು : 80]

[Max. Marks : 80

General Instructions to the Candidate :

1. There are *three* parts in the question paper :
Part A : Physics, Part B : Chemistry, Part C : Biology.
2. This question paper consists of 38 questions.
3. Follow the instructions given against the questions.
4. Figures in the right hand margin indicate maximum marks for the questions.
5. The maximum time to answer the paper is given at the top of the question paper. It includes 15 minutes for reading the question paper.

PPT-1029

[Turn over

III. Answer the following questions :

3 × 2 = 6

6. Draw the schematic diagram of a bio-gas plant.
7. Observe the given diagram. What conclusions can be drawn from the experiment related to this diagram ?

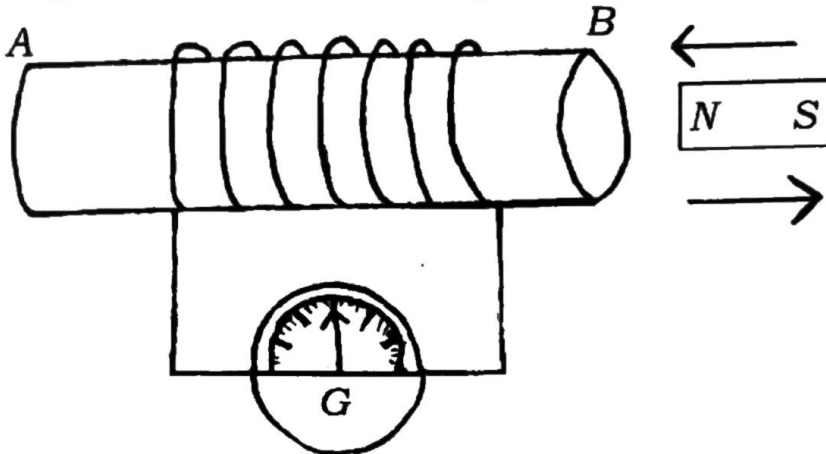

8. An optician has prescribed a corrective lens of power + 3 D to a person. What eye defect that person has ? What is the type of this lens and what is the focal length of the same lens ?

IV. Answer the following questions :

3 × 3 = 9

9. a) What is an electric motor ? State the rule that helps to detect the direction of mechanical force on a conductor in an electric motor.
- b) What is the role of split rings in the motor ?

OR

- a) State right hand thumb rule.
- b) Mention any two properties of magnetic field lines.
- c) What are the two methods of increasing magnetic field in a solenoid ?

10. Draw the ray diagram for the image formation in a concave mirror when the object is placed between C and F . Mention the position and the nature of the image formed with the help of ray diagram.

[C : Centre of curvature]
 [F : Principal focus]

11. Observe the given circuit diagram :

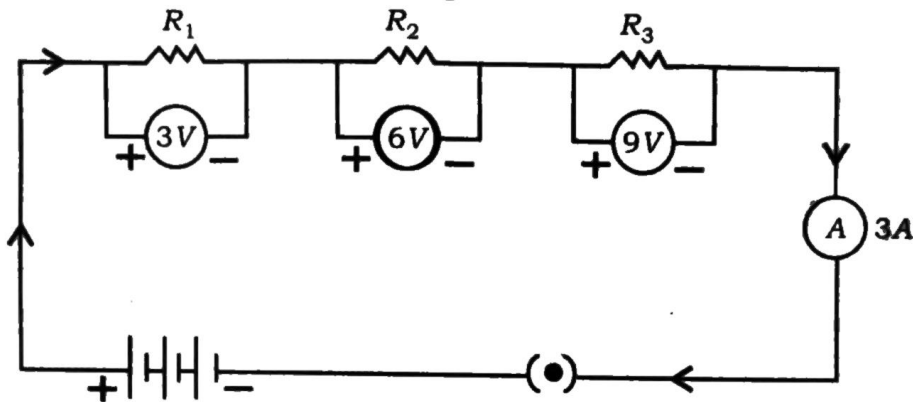

Calculate the total resistance of this circuit.

V. Answer the following questions :

2 × 4 = 8

12. An experiment is conducted in a circuit using nichrome wire. Below given the values of potential difference (V) between the two ends of the wire and current (I) passed through it in a table. Observe the table and answer the questions :

I (in ampere)	0.5	1.0	1.5	2.0
V (in volt)	1.5	3.0	4.5	6.0

- a) i) State the law related to this experiment.
 ii) What is the resistance of the nichrome wire ?

- b) In domestic electric circuit electrical appliances are not connected in series. Why ? Explain.

OR

- a) Electrical resistivity of some substances at 20°C are given in the following table. Observe the table and answer the given questions :

<i>Substance</i>	<i>Resistivity (Ω m)</i>
Silver	1.60×10^{-8}
Aluminium	2.63×10^{-8}
Nichrome	100×10^{-6}
Ebonite	$10^{15} \times 10^{17}$

- i) Which of these substances is a good conductor and which of them is an insulator ? Why ?
- ii) Which substance is used in electrical heating devices ? Why ?
- b) When current flows through a circuit having tungsten wire of particular length, then ammeter reading is 5 A. What change does occur in the ammeter reading when the thickness of the tungsten wire of the same length is doubled ? Why ?
13. a) The refractive indices of material media A and B are 1.50 and 1.44 respectively.
- i) Which medium is optically denser ? Why ?
- ii) In which medium speed of light is more ? Why ?
- b) The magnification of the image of an object obtained from a lens is - 1. What type of lens is to be used to get this image ? Mention the position, nature and the size of this image.

PART - B

(CHEMISTRY)

VI. Four alternatives are given for each of the following questions / incomplete statements. Choose the correct alternative and write the complete answer along with its letter of alphabet. $2 \times 1 = 2$

14. The substance reduced in the chemical reaction

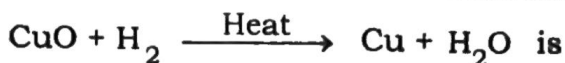

- (A) H_2 (B) Cu
(C) CuO (D) H_2O

15. Correct structure of Benzene is

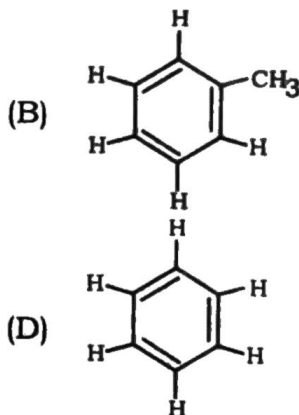
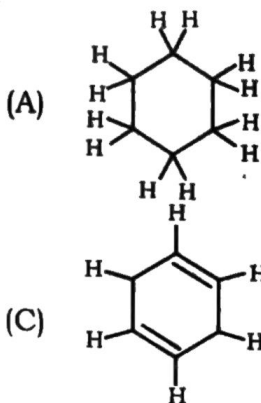

VII. Answer the following question :

$1 \times 1 = 1$

16. State 'Modern Periodic law'.

VIII. Answer the following questions :

$2 \times 2 = 4$

17. When blue and red litmus papers are dipped separately in the both of given below solutions what changes can be observed ? Give reason.

Solution X : Magnesium hydroxide

Solution Y : Acetic acid.

18. With the help of the given part of modern periodic table below, choose the element having smaller atomic size and the element having larger atomic size. Mention the reason for your choice.

3rd period
elements →

Na	Mg	Al	Si	P	S	Cl
----	----	----	----	---	---	----

OR

How does the metallic property vary in the elements that belong to the same group of modern periodic table? Give reason for this change.

IX. Answer the following questions :

3 × 3 = 9

19. a) Name the electrolyte solution used in the refining of copper.
- b) List the methods of preventing corrosion of metals.
20. Balance the following chemical equations :
- i) $\text{Fe} + \text{H}_2\text{O} \rightarrow \text{Fe}_3\text{O}_4 + \text{H}_2$
- ii) $\text{H}_2 + \text{O}_2 \rightarrow \text{H}_2\text{O}$
- iii) $\text{CH}_4 + \text{O}_2 \rightarrow \text{CO}_2 + \text{H}_2\text{O}$

OR

Write the balanced chemical equations for the following statements :

- i) Silver chloride gives, silver and chlorine in the presence of sunlight.
- ii) Sodium sulphate and barium chloride react with each other to give barium sulphate and sodium chloride.

21. Draw the diagram of arrangement of apparatus to show the action of steam on a metal. Label the following parts :

- i) Metal sample
- ii) Delivery tube.

X. Answer the following question :

1 × 4 = 4

22. a) pH values of *K*, *L*, *M* and *N* solutions are 5, 13, 9 and 3 respectively. Which of these solutions is having maximum hydrogen ions and which solution is having maximum hydroxide ions ?

b) A saturated solution *P* is subjected to electrolysis. In this process the gas *Q* released at the anode is passed through a basic solution *R* to form a bleaching salt *S*. Then what are these *P*, *Q*, *R* and *S* substances ?

XI. Answer the following question :

1 × 5 = 5

23. a) Methanol is the first member in a homologous series. Write the names and molecular formulae of the second and third members of the same series.

b) Which one of the carbon compounds having molecular formulae C_2H_4 and C_2H_6 can undergo addition reaction ? Explain this reaction with suitable equation.

PART - C

(BIOLOGY)

XII. Four alternatives are given for each of the following questions / incomplete statements. Choose the correct alternative and write the complete answer along with its letter of alphabet. $4 \times 1 = 4$

24. Products formed in the muscle cells by the respiration carried out in the lack of oxygen are
- (A) Ethanol and carbon dioxide
 - (B) Carbon dioxide and water
 - (C) Lactic acid and energy
 - (D) Pyruvate and energy
25. Homologous organs mean
- (A) Organs that are similar in structure but different in function
 - (B) Organs that are different in structure but similar in function
 - (C) Organs that are similar in both structure and function
 - (D) Organs that are different in both structure and function
26. The process of transpiration in the plant body
- (A) Balances the amount of oxygen and water
 - (B) Helps to create a column of water in xylem tissue
 - (C) Helps to transport soluble products for photosynthesis
 - (D) Creates osmotic pressure
27. A sexually reproducing animal has 39 pairs of chromosomes. Then, the number of chromosomes in the zygote of this animal is
- (A) 39
 - (B) 78
 - (C) 87
 - (D) 93

XIII. Answer the following questions :**4 × 1 = 4**

28. Figure A and Figure B are the hearts of higher animals. Which of these heart structures helps for the production of more energy ?
Why ?

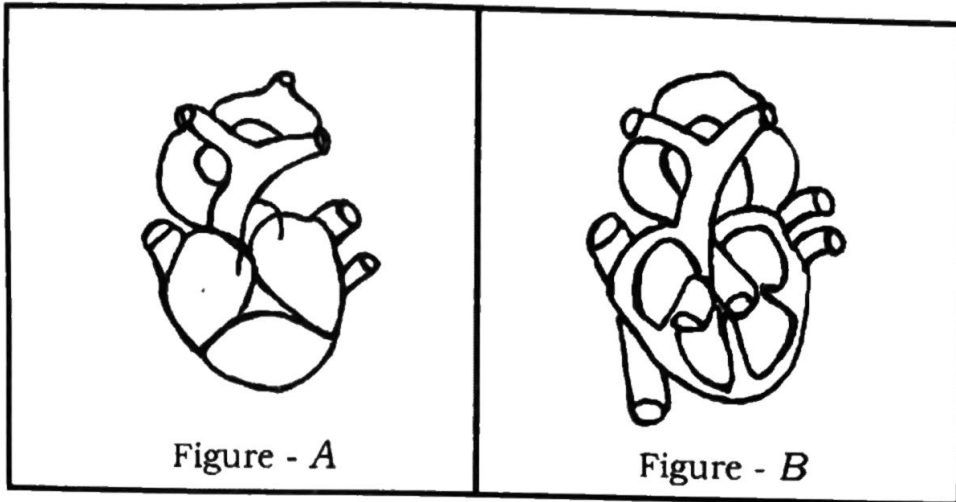

29. Sexual reproduction results more variations in the offsprings.
Why ?
30. What is the function of adrenaline hormone ?
31. What is pollination ?

XIV. Answer the following questions :**3 × 2 = 6**

32. Draw the diagram showing the structure of human excretory system and label 'Urinary bladder'.
33. Who are the stakeholders of the forests ?

OR

List any four eco-friendly measures that can be taken to reduce the impact of using fossil fuels on the environment.

34. Draw the diagram showing the structure of 'neuron' and label 'axon'.

XV. Answer the following questions :**3 × 3 = 9**

35. Tall pea plants (Tt) are crossed with short pea plants (tt). Show the results of the F_2 generation with the help of a checker board. Based on this result differentiate between dominant traits and recessive traits.

OR

- a) What factors could lead to the rise of a new species ?
- b) The experiences gained by an organism cannot be transferred to the organisms of next generation. Why ?
36. a) Why are food webs formed in any ecosystem ?
- b) Biodegradable wastes and non-biodegradable wastes are to be dumped into separate dustbins. Why ?
37. "Vegetative type of reproduction is a boon to farmers." How ?

OR

How are (i) the position of testis (ii) the function of uterus complementary to each other in human reproduction ? Explain.

XVI. Answer the following question :**1 × 4 = 4**

38. How are cerebrum, cerebellum and medulla of the brain bring control and co-ordination in our body ?